

KEGELRADGETRIEBE TYP V 350

BEVEL GEARBOX TYPE V 350

Das neue V 350: größer, stärker – ATEK

Die ATEK V-Serie bekommt Verstärkung. War bisher das V 260 das größte Kegelradgetriebe des ATEK Baukastensystems, setzt nun das V 350 neue Maßstäbe. Für sehr hohe Drehmomente ausgelegt, besitzt es gleichzeitig alle typischen ATEK Qualitäten wie Robustheit, Ganggenauigkeit und Übersetzungsvielfalt. Ausgezeichnete Lieferfähigkeit inklusive.

The new V 350: bigger, stronger – ATEK

The ATEK type V range has been expanded. Whereas the V 260 was so far the largest bevel gearbox of the ATEK modular system, the V 350 now sets new standards. Designed for very high torques, at the same time it possesses all the typical ATEK qualities such as robustness, precise running and a wide variety of transmission ratios. Including excellent delivery capacity.

Leistungen, Drehmomente / Power Ratings, Torque Ratings [n = min-1, P = kW, T = Nm]

i = n1	1:1 n2	P1N T2N	1,5:1 n2	P1N T2N	2:1 n2	P1N T2N	3:1 n2	P1N T2N	4:1 n2	P1N T2N	5:1 n2	P1N T2N	6:1 n2	P1N T2N
3000	3000		2000		1500		1000		750		600		500	
2400	2400		1600		1200		800	160,48 1820	600	113,75 1720	480	78,83 1490	400	56,88 1290
1500	1500	267,84 1620	1000	206,19 1870	750	200,06 2420	500	122,35 2220	375	78,95 1910	300	56,54 1710	250	41,61 1510
1000	1000	210,53 1910	667	188,55 2560	500	155,41 2820	333	96,26 2620	250	58,14 2110	200	42,33 1920	167	31,41 1710
750	750	195,92 2370	500	141,42 2560	375	129,37 3130	250	81,29 2950	187,5	47,95 2320	150	35,88 2170	125	24,25 1760
500	500	155,41 2820	333	112,63 3070	250	94,52 3430	167	59,34 3230	125	34,72 2520	100	26,67 2420	83	16,72 1820
250	250	94,52 3440	167	67,11 3650	125	54,15 3930	83	34,26 3730	62,5	19,43 2820	50	16,09 2920	42	9,28 2020
50	50	24,47 4440	33	16,34 4500	25	12,79 4640	17	7,79 4240	12,5	4,17 3030	10	3,56 3230	8,3	1,95 2120
P1Nt		90		90		90		90		90		90		90
T2max		5400		5200		5000		4500		3500		3500		2300

Schnittzeichnung / Section Drawing

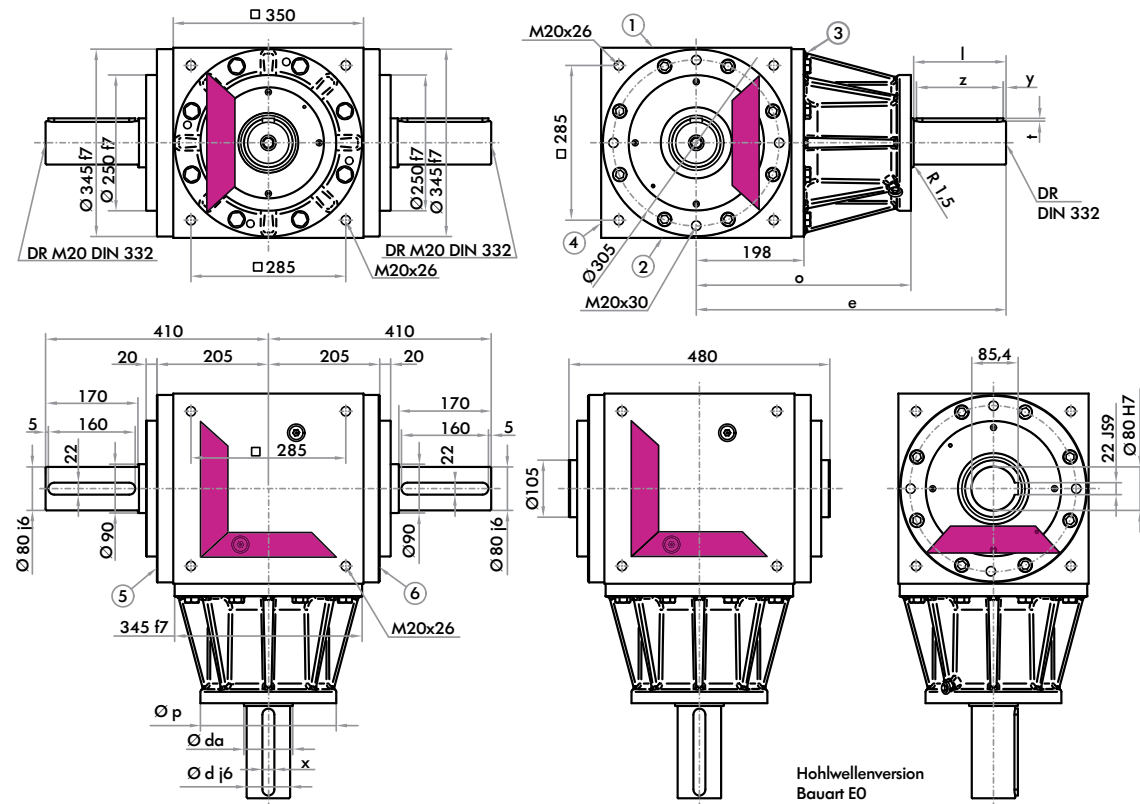

Bauart / Model

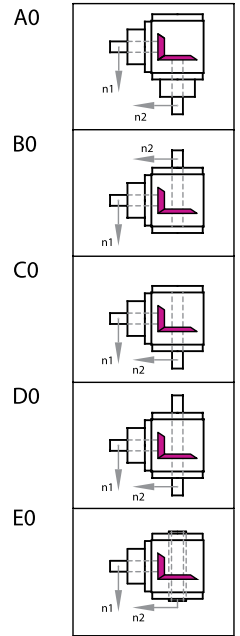

Abmessungen in Abhängigkeit von der Übersetzung / Dimensions depending on Transmission Ratios

Übers./Ratio	d	da	l	v	x	y	z	t	DR	e	o	p
i = 1:1 - 2:1	80	90	170	1,5	22	5	160	5	M20	570	395	250

Übers./Ratio	d	da	l	v	x	y	z	t	DR	e	o	p
i = 3:1	65	90	140	1,5	18	7,5	125	4	M20	540	395	250

Übers./Ratio	d	da	l	v	x	y	z	t	DR	e	o	p
i = 4:1	65	90	140	1,5	18	7,5	125	4	M20	540	395	250

Übers./Ratio	d	da	l	v	x	y	z	t	DR	e	o	p
i = 5:1 - 6:1	55	72	110	1,5	16	10	90	4	M20	510	395	250

Befestigungsseite / Mounting Side

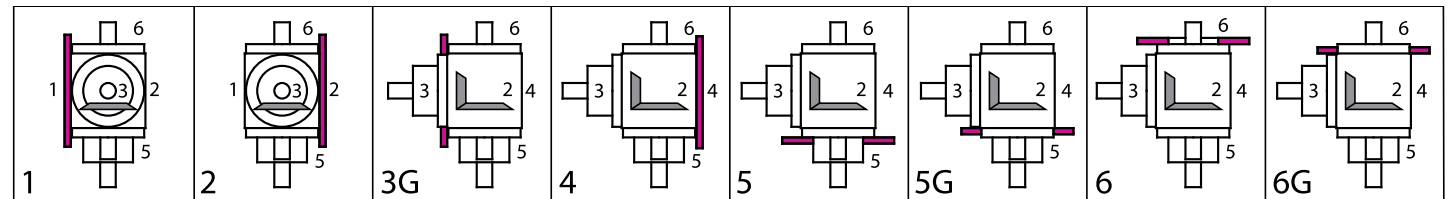

Einbaulagen (unten liegende Getriebeseite) / Mounting Configuration (downward-facing side)

